



NSW Education Standards Authority

**2019** HIGHER SCHOOL CERTIFICATE EXAMINATION

# Engineering Studies

---

**General  
Instructions**

- Reading time – 5 minutes
- Working time – 3 hours
- Write using black pen
- Draw diagrams using pencil
- Calculators approved by NESA may be used
- A formulae sheet is provided at the back of this paper

---

**Total marks:  
100**

**Section I – 20 marks** (pages 2–11)

- Attempt Questions 1–20
- Allow about 30 minutes for this section

**Section II – 80 marks** (pages 13–36)

- Attempt Questions 21–27
- Allow about 2 hours and 30 minutes for this section

## Section I

20 marks

Attempt Questions 1–20

Allow about 30 minutes for this section

Use the multiple-choice answer sheet for Questions 1–20.

---

- 1 Which Australian aeronautical innovation is commonly used to record in-flight data?
- A. Altimeter
  - B. Pitot tube
  - C. Black box
  - D. Transponder
- 2 Which of the following identifies TWO properties of polymers that make them better suited than ceramics for the insulation of telecommunication cables?
- A. Ease of formability and higher density
  - B. Ease of formability and higher flexibility
  - C. Higher resistance to abrasion and higher density
  - D. Higher resistance to abrasion and higher flexibility
- 3 Which AND gate shows the correct output for its given inputs?

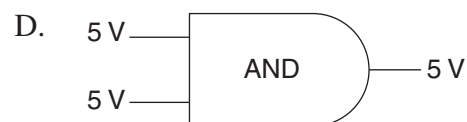
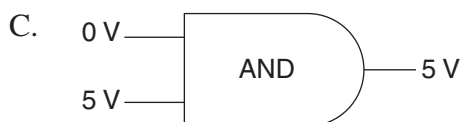
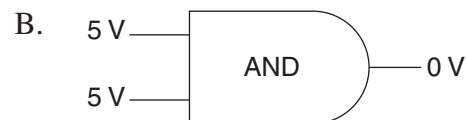
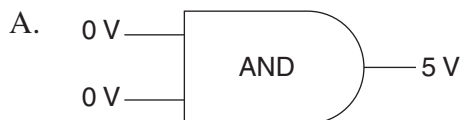

- 4 A general purpose bolt drawn to AS 1100 drawing standards is shown.

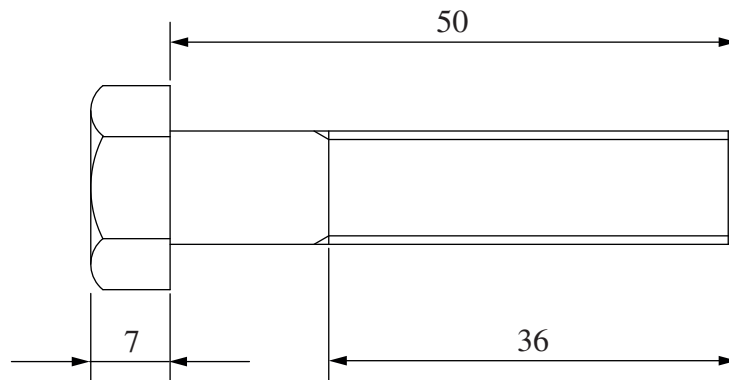

What is the diameter of the bolt?

- A. 8.75 mm
  - B. 10.00 mm
  - C. 14.00 mm
  - D. 18.00 mm
- 5 Using computer-aided drawing (CAD) software a new outline was produced 18.32 mm away from the original outline of an item as shown.

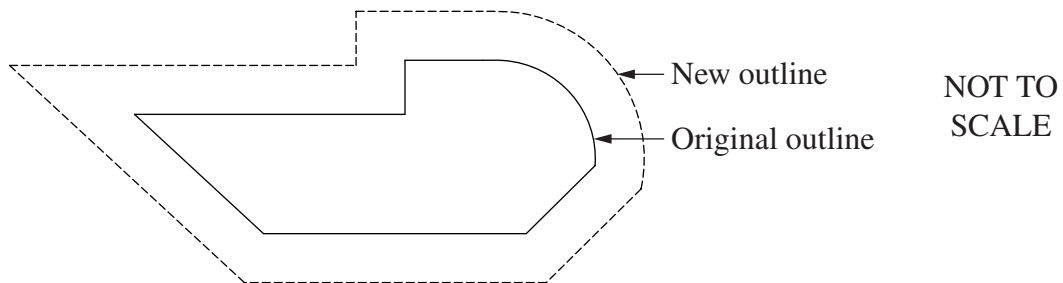

Which CAD command can produce this result most efficiently?

- A. Trim
- B. Offset
- C. Mirror
- D. Expand

- 6 The schematic diagram shows a bridge rectifier.

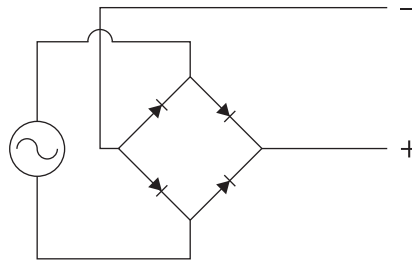

What is the function of this bridge rectifier?

- A. To increase voltage
  - B. To decrease voltage
  - C. To convert DC to AC
  - D. To convert AC to DC
- 7 A box sits on a horizontal surface. The box begins to slip when this surface is tilted to 28 degrees.

What is the coefficient of friction between the box and the surface?

- A. 0.280
  - B. 0.469
  - C. 0.532
  - D. 0.883
- 8 Which row of the table correctly identifies the routine maintenance responsibilities of an aeronautical engineer working for a small commercial airline?

	<i>Design of modifications</i>	<i>Construction of prototypes</i>	<i>Certification of repairs</i>	<i>Supervision of maintenance</i>
A.	×	×	✓	✓
B.	✓	×	×	✓
C.	✓	✓	×	×
D.	×	✓	✓	×

- 9 A sketch of a post-tensioned concrete beam is shown.

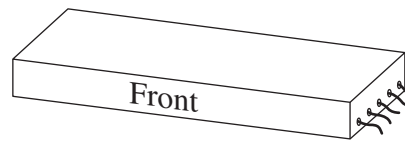

Which of the following shows the most likely loading condition the beam is designed to resist when viewed from the front?

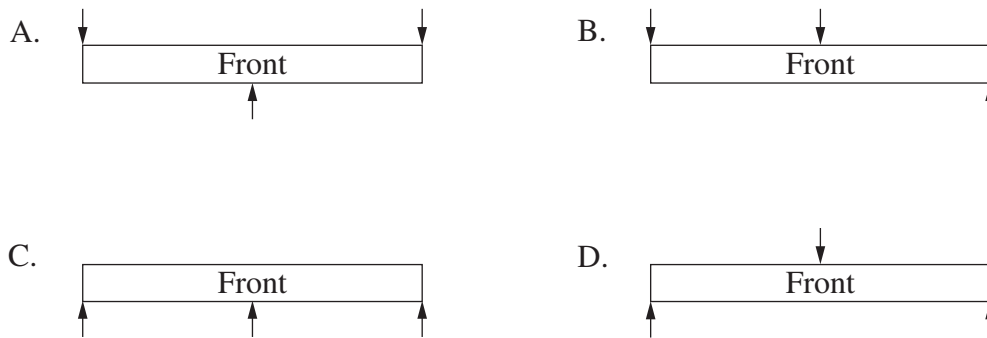

- 10 The diagram shows the airflow in a venturi.

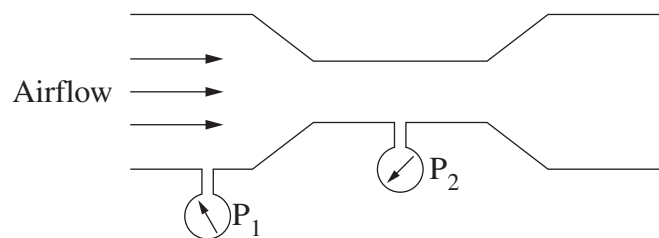

What does this diagram illustrate?

- A. Coriolis effect
- B. Pascal's principle
- C. Dynamic pressure
- D. Bernoulli's principle

11 The table shows materials that have been used to build civil structures over time.

Which row of the table shows the use of the materials in the correct historical order?

	<i>Earliest</i> →		
A.	Stone	Cast iron	Alloy steel
B.	Wrought iron	Stone	Alloy steel
C.	Timber	Stainless steel	Mild steel
D.	Cast iron	Stainless steel	Mild steel

12 Which row of the table indicates the effects of retrofitting winglets to a plane?

	<i>Lift</i>	<i>Drag</i>	<i>Vortices</i>
A.	Decreases	Decreases	Decrease
B.	Increases	Decreases	Decrease
C.	Decreases	Increases	Increase
D.	Increases	Increases	Increase

13 The diagram shows a seesaw being used by two children, one of mass 25 kg and the other of mass 20 kg. It has a corroded pivot mechanism that reduces its efficiency by 25%.

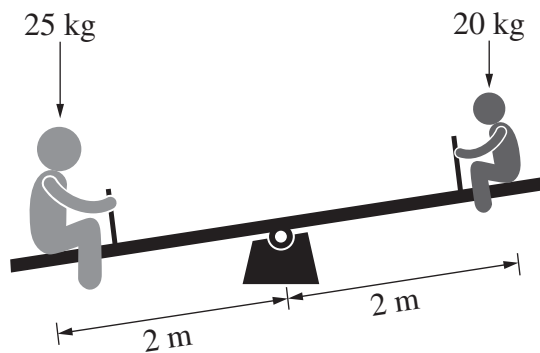

What is the mechanical advantage of the seesaw?

- A. 0.25
- B. 0.75
- C. 0.80
- D. 1.00

- 14 Which row of the table correctly identifies key features of analogue and digital signals used in the transmission of television in Australia?

	<i>Analogue television signals</i>	<i>Digital television signals</i>
A.	FM signals used to transmit audio	MP2 or MP4 compression used to transmit video
B.	AM signals used to transmit audio	MP2 or MP4 compression used to transmit video
C.	FM signals used to transmit luminescence	VOIP used to transmit video
D.	AM signals used to transmit luminescence	VOIP used to transmit video

- 15 Titanium is used to manufacture aircraft undercarriages that support landing wheels.

Why is titanium used in preference to alloy steel for this purpose?

- A. It has lower density and lower strength.
- B. It has lower density and higher strength.
- C. It has higher density and lower strength.
- D. It has higher density and higher strength.

- 16 The image shows part of a large anchor recovered from waters off Western Australia. The anchor's approximate date of manufacture was 1790.



This anchor is most likely made from

- A. cast iron.
  - B. cast steel.
  - C. wrought iron.
  - D. laminated silicon steel.
- 17 Which row of the table correctly identifies the rolling process used to manufacture each of the components listed at room temperature?

	<i>Lead alloy battery plates</i>	<i>Steel body panels</i>
A.	Cold rolling	Cold rolling
B.	Cold rolling	Hot rolling
C.	Hot rolling	Cold rolling
D.	Hot rolling	Hot rolling



- 18 A scooter shock absorber is compressed from 120 mm to 90 mm when an average compressive force of 400 N is applied.

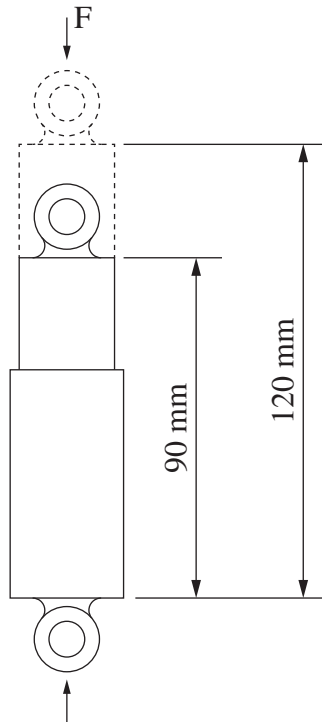

What is the energy stored in this shock absorber?

- A. 12 J
- B. 36 J
- C. 48 J
- D. 120 J

19 A webbed flange is shown.

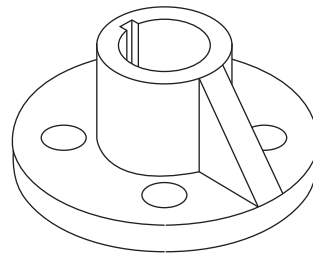
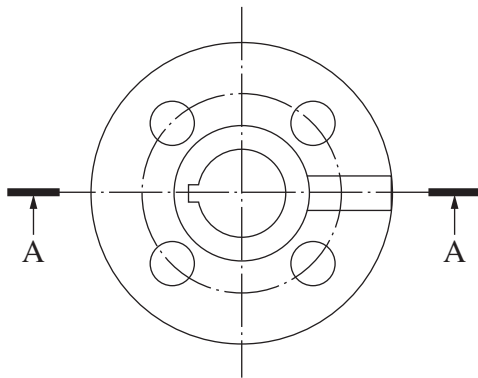

NOT TO  
SCALE

Which image correctly represents section A-A?

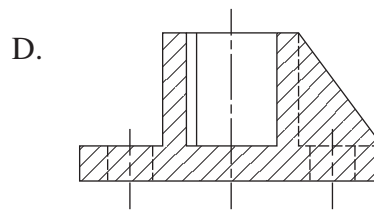
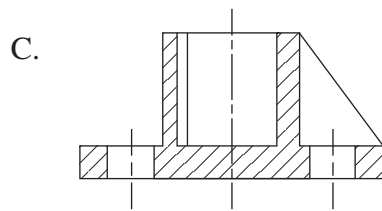
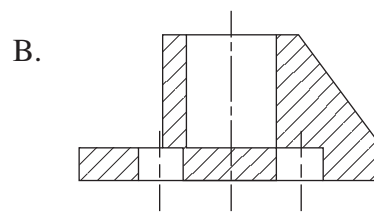
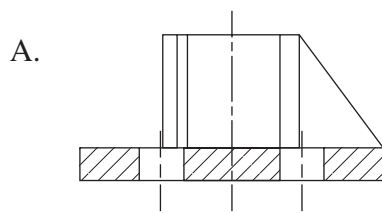

- 20 An annealed copper tensile test specimen has an original cross-sectional area (CSA) of  $100 \text{ mm}^2$ .

During testing, an engineering stress of  $150 \text{ MPa}$  is induced within the specimen before necking occurs. At this strain the CSA reduces uniformly by  $10\%$  to  $90 \text{ mm}^2$ .

This is illustrated in the diagrams below.

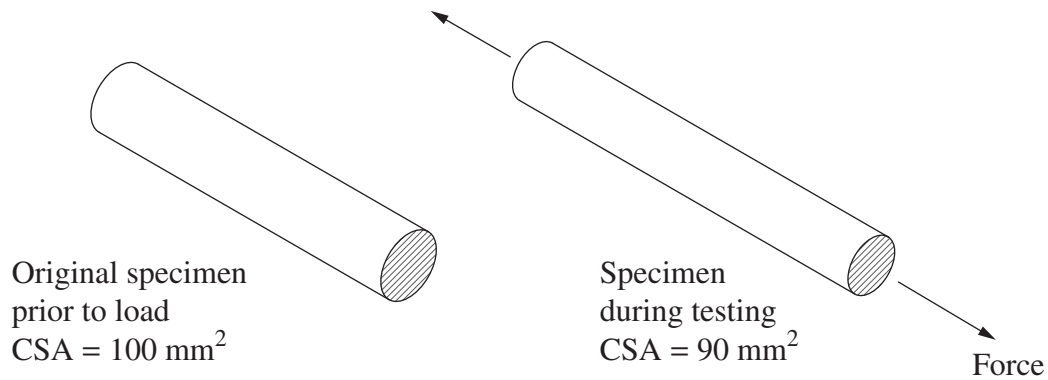

What is the value of the true stress induced at this strain?

- A.  $135.0 \text{ MPa}$
- B.  $136.4 \text{ MPa}$
- C.  $150.0 \text{ MPa}$
- D.  $166.7 \text{ MPa}$

BLANK PAGE

--	--	--	--	--

Centre Number

# Engineering Studies

## Section II Answer Booklet

--	--	--	--	--	--	--	--	--

Student Number

**80 marks**

**Attempt Questions 21–27**

**Allow about 2 hours and 30 minutes for this section**

**Instructions**

- Write your Centre Number and Student Number at the top of this page.
- Answer the questions in the spaces provided. These spaces provide guidance for the expected length of response.
- Show all relevant working in questions involving calculations.

---

**Please turn over**

**Question 21** (12 marks)

A bus shelter is shown.

Due to copyright restrictions, this material cannot be displayed until permission has been obtained.

- (a) The design of this bus shelter includes the use of toughened glass panels. **3**

Outline advantages of using toughened glass for this bus shelter.

.....  
.....  
.....  
.....  
.....

- (b) A laminated timber beam is used as part of the roof construction for this bus shelter. **2**

Apart from cost and aesthetics, justify why laminated timber would be selected for this structure.

.....  
.....  
.....  
.....

**Question 21 continues on page 15**

Question 21 (continued)

- (c) Describe a testing procedure that could be used to determine the structural strength of the laminated timber beam. Support your answer with a labelled sketch.

4

.....

.....

.....

.....

.....

.....

.....

.....

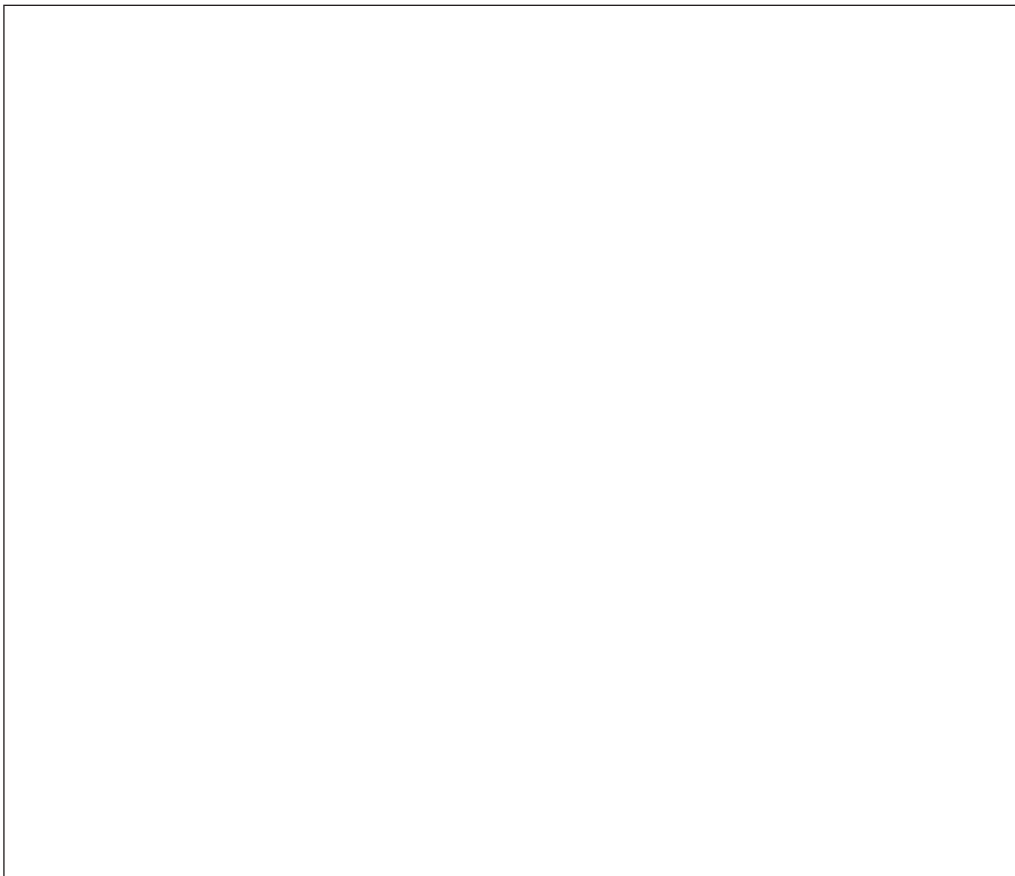

Do NOT write in this area.

**Question 21 continues on page 16**

Question 21 (continued)

- (d) A pictorial sketch of a laminated timber beam used in a bus shelter is shown. This beam has a second moment area of  $117 \times 10^{-6} \text{ m}^4$ . The maximum applied bending moment is 17 kNm.

3

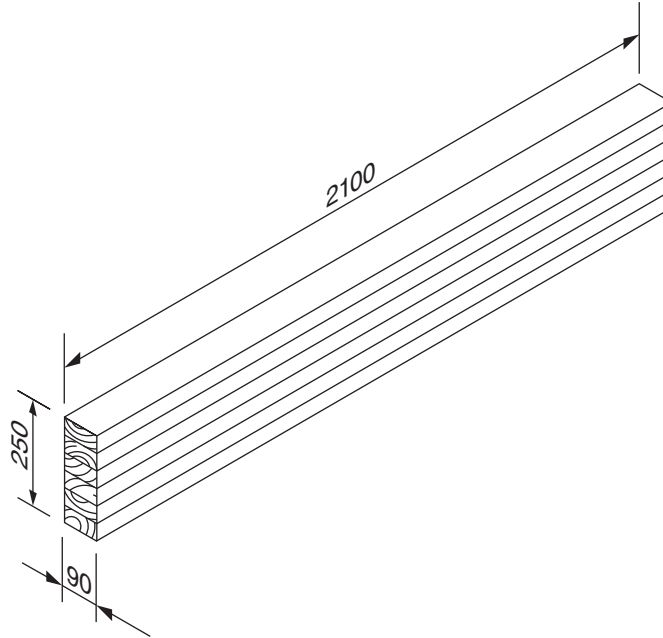

Calculate the maximum bending stress present in the beam.

Answer: ..... MPa

**End of Question 21**



**Question 22** (12 marks)

A telecommunications engineer has designed a tower that is to support two mobile repeater transmitters. It is to be located in an urban community.

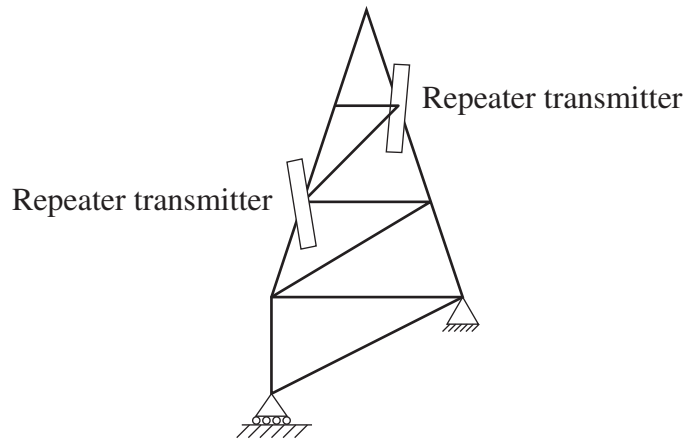

- (a) Outline responsibilities the engineer has when placing the tower within a local community. **3**

.....

.....

.....

.....

.....

.....

.....

.....

.....

.....

- (b) Explain why the engineer has positioned the repeater transmitters as indicated on the diagram. **3**

.....

.....

.....

.....

.....

.....

.....

.....

.....

.....

**Question 22 continues on page 18**

Do NOT write in this area.

Question 22 (continued)

- (c) The diagram shows some dimensions and forces associated with the telecommunications tower. 6

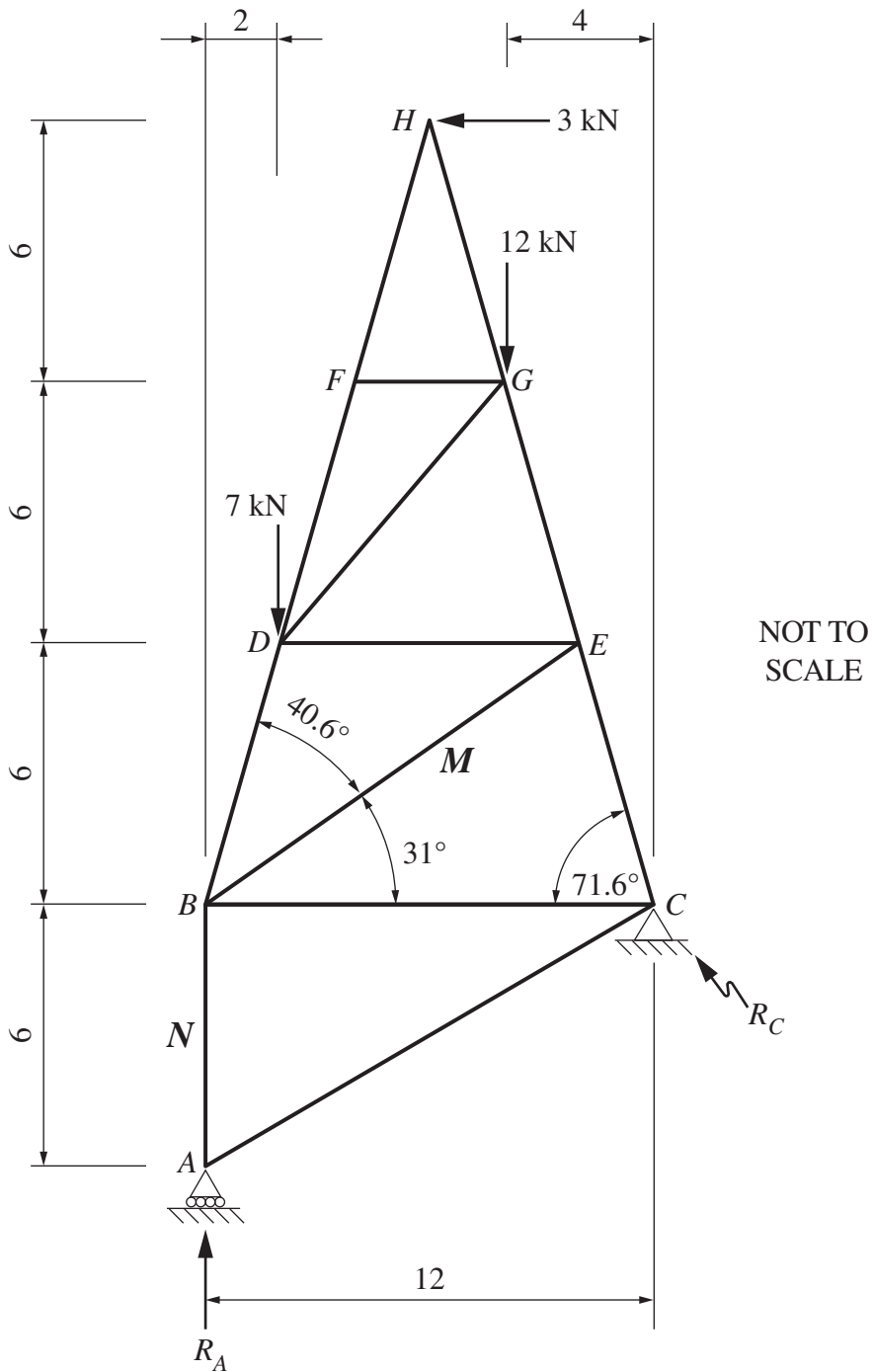

Do NOT write in this area.

Question 22 continues on page 19

Question 22 (continued)

By considering any necessary reaction, calculate the magnitude of the forces in members  $M$  and  $N$ . State the nature of each force. Ignore the weight of the tower.

Do NOT write in this area.

	<i>Magnitude</i>	<i>Nature</i>
Force in $M$	.....	.....
Force in $N$	.....	.....

**End of Question 22**

**Question 23** (11 marks)

A scooter and rider enter the half pipe shown at a velocity of 3 m/s. The scooter and rider have a combined mass of 55 kg.

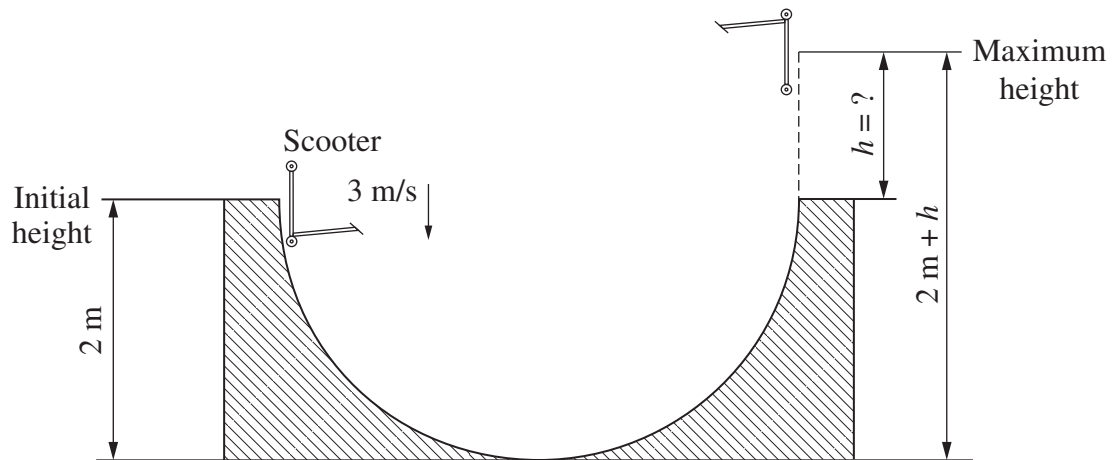

- (a) Calculate the maximum height,  $h$ , the scooter and rider will reach above the other side of the pipe wall. Assume no loss of energy.

3

Answer: ..... m

**Question 23 continues on page 21**

Question 23 (continued)

- (b) An electric scooter is powered by a 12-volt rechargeable battery with a capacity of 18 Ah. 2

Calculate the energy stored in the battery. Use  $1 \text{ Wh} = 3600 \text{ J}$ .

Do NOT write in this area.

Answer: ..... kJ

**Question 23 continues on page 22**

Question 23 (continued)

- (c) The weight of a 650 N rider and the mass of the scooter are evenly distributed between the front and rear pneumatic tyres. The area of contact between each of the two tyres and the ground is  $1200 \text{ mm}^2$ . The pressure inside each tyre is 300 kPa.

3

What is the mass of the scooter?

Answer: ..... kg

Do NOT write in this area.

Question 23 continues on page 23

Question 23 (continued)

(d) A scooter deck, made from aluminium alloy, and its cross-section are shown.

3

Due to copyright restrictions, this material cannot be displayed until permission has been obtained.

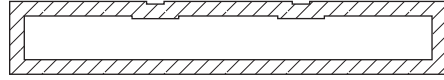

Cross-section of current scooter deck

NOT TO SCALE

The scooter's manufacturer is concerned that there is too much deflection along the length of the deck when a rider stands on it.

Describe ONE suitable design modification to give the deck greater rigidity without adding extra mass. Use a labelled sketch to support your answer.

.....

.....

.....

.....

.....

.....

End of Question 23

Do NOT write in this area.

**Question 24** (13 marks)

An image of an aeroplane is shown with the position of the wing support beam indicated.

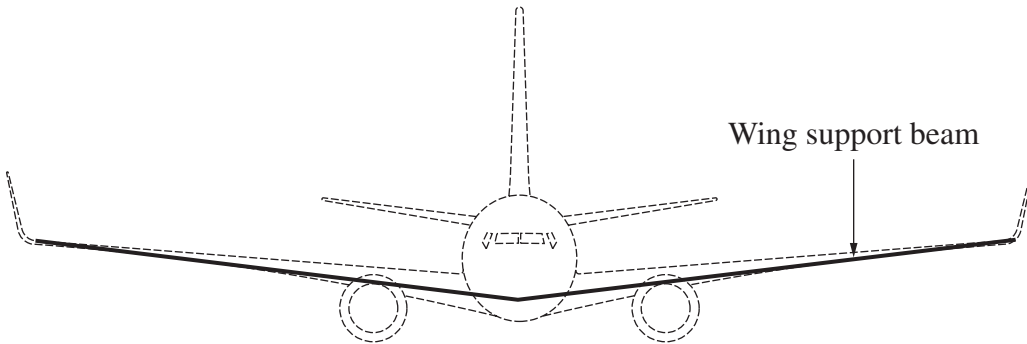

Assume the engines are supported by the single beam. The beam runs through the plane, wing tip to wing tip.

- (a) Compare the use of composite materials with the use of metals for the manufacture of the beam. 3

.....

.....

.....

.....

.....

.....

.....

.....

.....

**Question 24 continues on page 25**

Do NOT write in this area.



Question 24 (continued)

(b) Normalised high-tensile steel has been chosen for the manufacture of the wing support beam.

(i) Draw and label the microstructures of a normalised high-tensile steel and an annealed high-tensile steel. 2

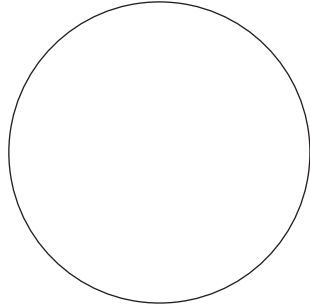

Normalised high-tensile steel

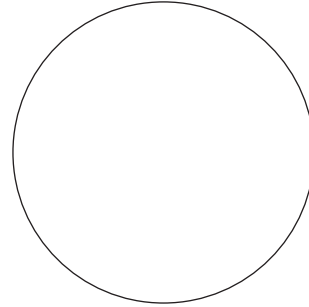

Annealed high-tensile steel

(ii) Explain how the microstructure produced by normalising high-tensile steel improves the steel's suitability for this application. 2

.....  
.....  
.....  
.....

**Question 24 continues on page 26**

Do NOT write in this area.

Question 24 (continued)

- (c) A drawing of an aircraft in flight is shown. This aircraft maintains a constant velocity when in level flight.

6

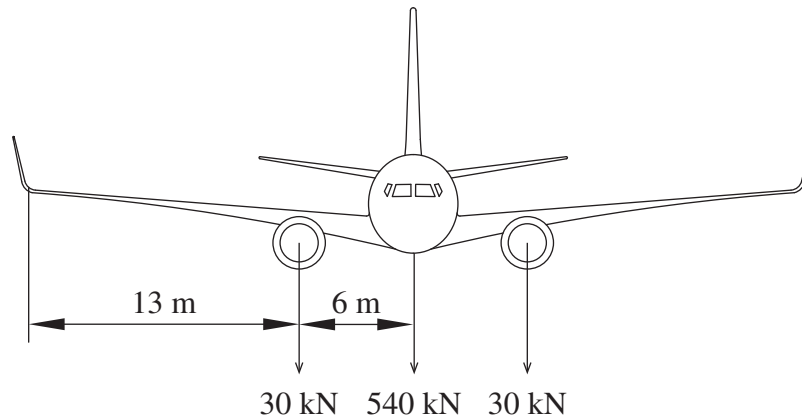

On the following page, draw a labelled shear force diagram AND a labelled bending moment diagram for this situation. Include a labelled free body diagram to support your answer.

Assume the centre of lift on each wing acts as a point load located 7.5 m from the centre line of the plane.

Calculations can be completed in the space below.

Do NOT write in this area.

Question 24 continues on page 27

Question 24 (continued)

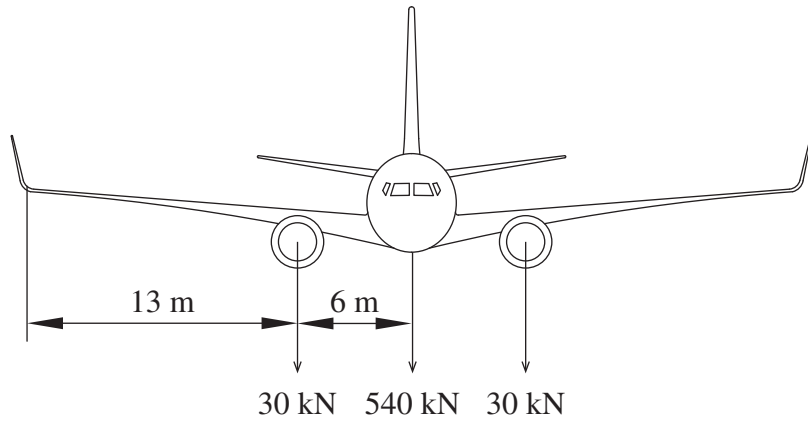

Free body diagram

Blank area for drawing the free body diagram.

Shear force diagram

Blank area for drawing the shear force diagram, consisting of a grid of horizontal and vertical dotted lines.

Bending moment diagram

Blank area for drawing the bending moment diagram, consisting of a grid of horizontal and vertical dotted lines.

**End of Question 24**

Do NOT write in this area.

**Question 25** (12 marks)

Modern racing yachts are now designed using aeronautical engineering principles.



(a) The diagram shows the hull of a racing yacht.

3

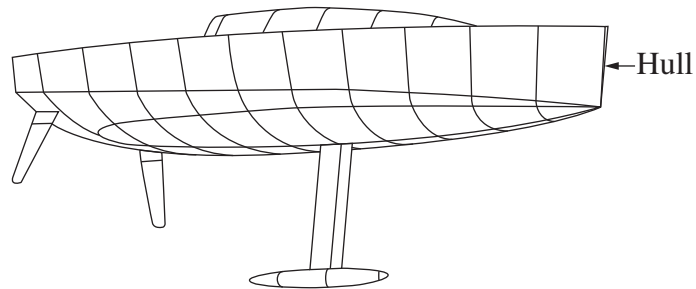

How can engineers use an understanding of the effects of drag to improve the design of racing yacht hulls?

.....

.....

.....

.....

.....

.....

**Question 25 continues on page 29**

Do NOT write in this area.

Question 25 (continued)

- (b) Some materials have properties that allow them to be used in the manufacture of both modern racing yachts and aircraft. These materials include Kevlar® aramid fibre, carbon fibre epoxy composites and aluminium alloys. 3

Complete the table by providing a property which makes each of these materials suitable for the manufacture of both yachts and aircraft.

<i>Material</i>	<i>Property</i>
Kevlar® aramid fibre	
Carbon fibre epoxy composite	
Aluminium alloy	

- (c) An intricate component used on racing yachts is shown below being modelled using computer-aided drawing (CAD) software. 3

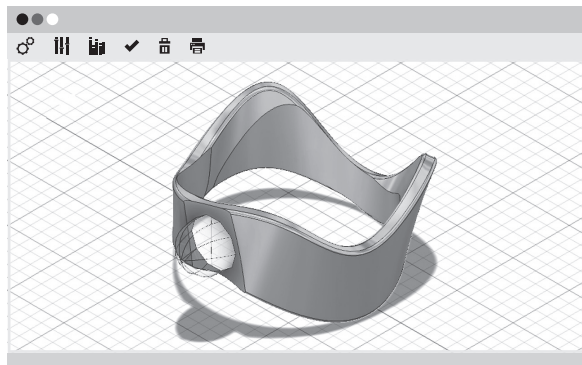

Explain why engineers use CAD software to design and model intricate components.

.....

.....

.....

.....

.....

.....

.....

**Question 25 continues on page 30**

Question 25 (continued)

- (d) The photograph shows a board with a hydrofoil attached underneath.

3

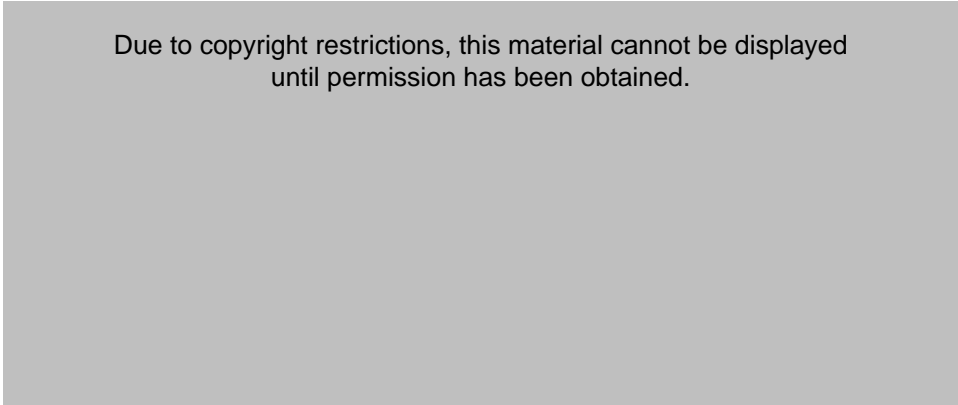

The hydrofoil is used to lift the board out of the water as the rider is towed behind a boat at high speed.

Explain why the hydrofoil can lift the board out of the water when it is travelling at high speed.

.....

.....

.....

.....

.....

.....

.....

.....

**End of Question 25**

Do NOT write in this area.

Do NOT write in this area.

**Question 26** (12 marks)

The photograph shows an AM radio coupled to a pedal-powered generator. This radio allowed communication in remote areas of Australia during the 1920s.

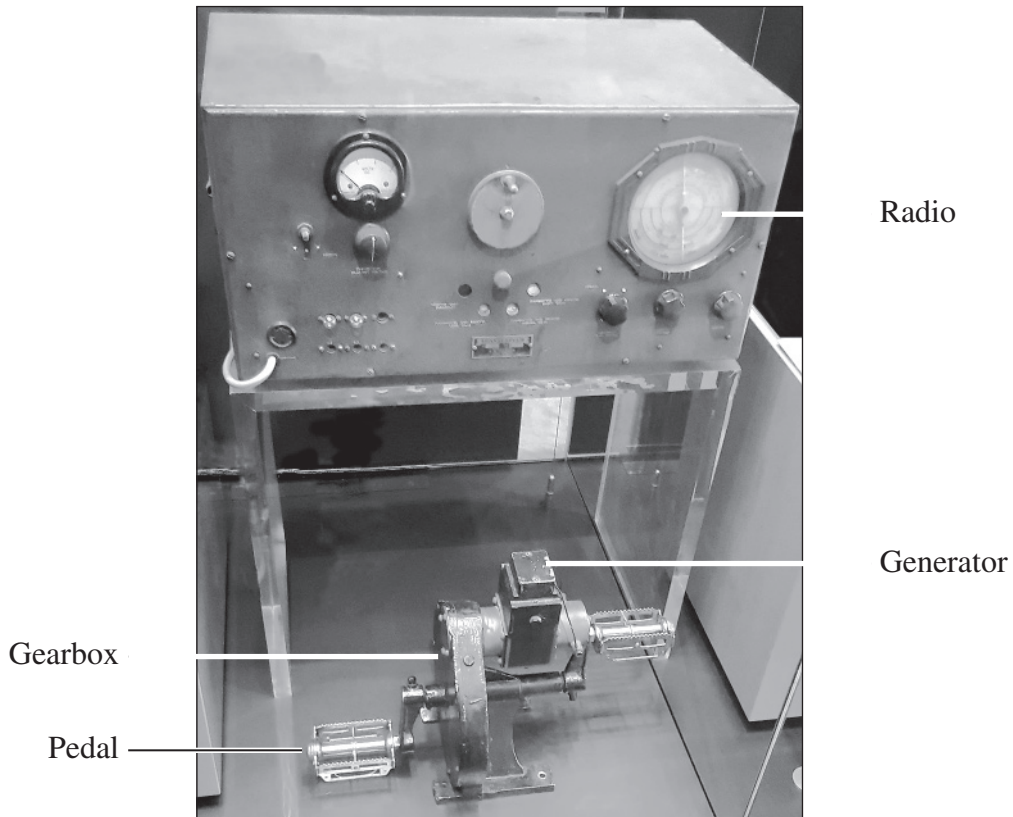

- (a) Explain how the mechanical energy from pedalling was converted into electrical energy in the generator to power the AM radio. **3**

.....

.....

.....

.....

.....

.....

.....

.....

.....

**Question 26 continues on page 32**

Question 26 (continued)

(b) A simple circuit diagram of the AM radio receiver is shown.

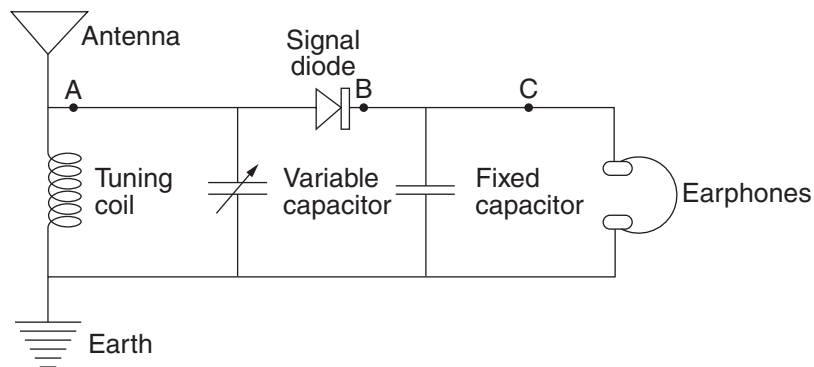

(i) Complete the table giving the function of each of the circuit components listed.

5



<i>Component</i>	<i>Function</i>
Antenna	
Capacitor (fixed)	
Capacitor (variable)	
Earphones	Converts electrical signal to sound
Earth	
Signal diode	

Question 26 continues on page 33

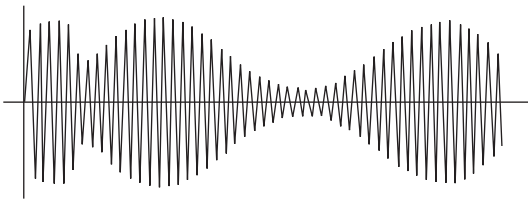

Question 26 (continued)

(ii) Complete the table by drawing the waveform at positions B and C. 2

<i>Position</i>	<i>Waveform</i>
A	
B	
C	

(iii) This AM radio receiver produced a demodulated electrical signal with a small current. The speakers in the earphones converted this signal into sound. 2

Explain why the speakers in the earphones required a high impedance (resistance) in order to produce sound of sufficient volume to be heard.

.....

.....

.....

.....

.....

.....

.....

.....

**End of Question 26**

Do NOT write in this area.

**Question 27** (8 marks)

A telecommunications tower with repeater transmitters is shown. The tower is assembled from many individual parts.

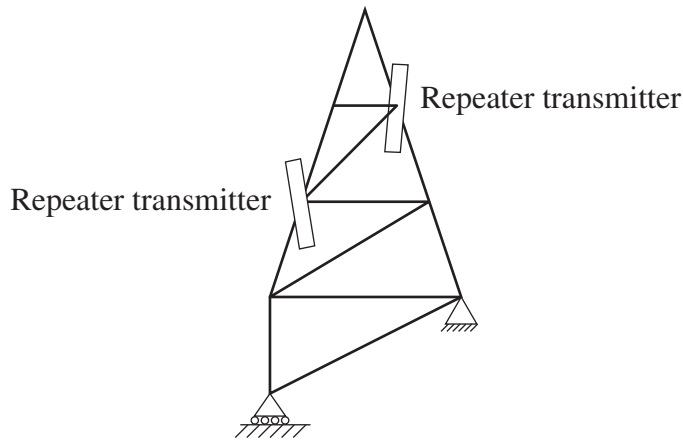

- (a) Explain why detailed drawings are used in the design and manufacture of these individual parts. 2

.....

.....

.....

.....

.....

.....

**Question 27 continues on page 35**

Question 27 (continued)

- (b) The bracket and lock pin assembly shown is used to attach the repeater transmitters to the tower.

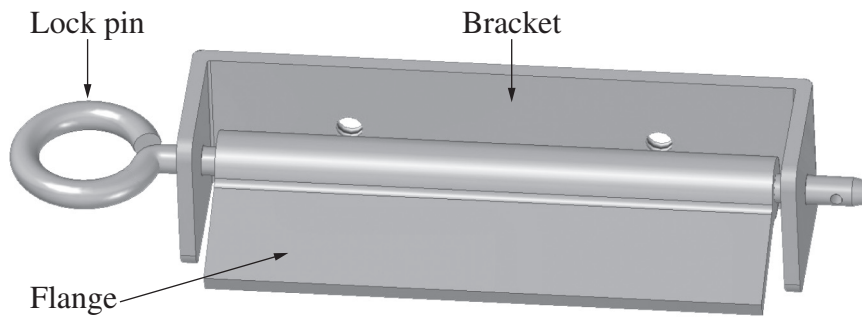

- (i) Using the data given, determine the minimum lock pin diameter to use. 3

Young's modulus	210 GPa
Factor of safety (FoS)	5
Total load	3.5 kN
Ultimate shear strength of pin	240 MPa
Available pin diameters (mm)	Ø5, Ø6, Ø7, Ø8, Ø9, Ø10

Answer:  $\varnothing = \dots\dots\dots$

**Question 27 continues on page 36**

Question 27 (continued)

- (ii) An assembly drawing of the bracket and lock pin with the flange removed is shown.

3

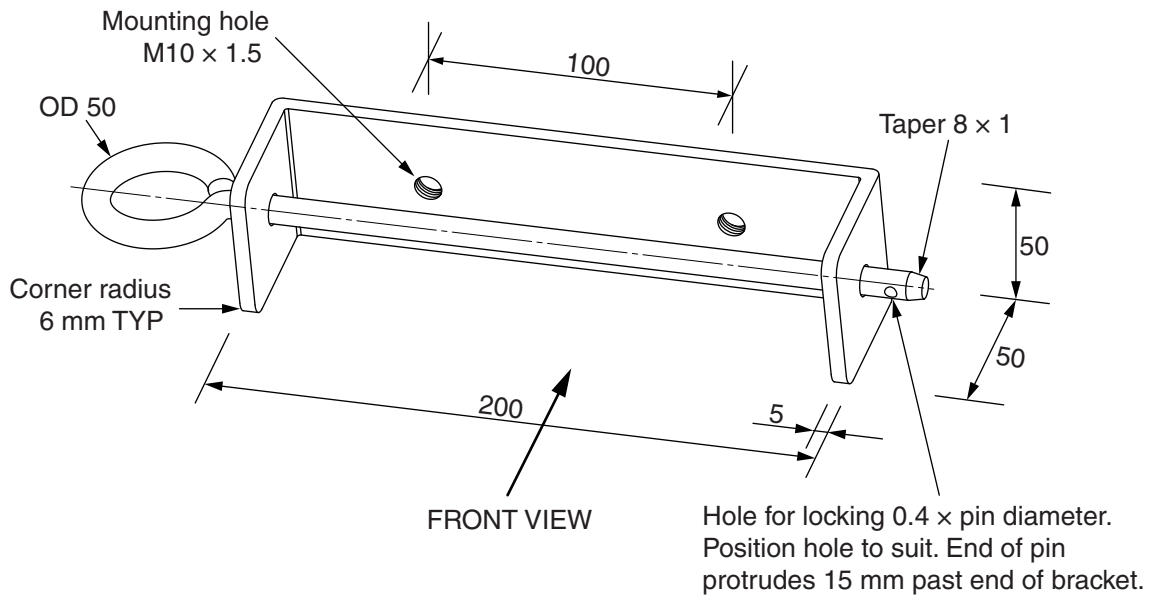

Using the starting lines and centre mark provided, draw a fully sectioned top view, to AS 1100 drawing standards. The section plane passes through the centre of the mounting holes. Use the dimensions on the drawing and the lock pin diameter determined in part (b) (i). Use a scale of 1 : 2.



Do NOT write in this area.

End of paper

# Engineering Studies

## FORMULAE SHEET

### Force, Moments

$$F = ma; \quad M = Fd$$

If a body is in equilibrium, then  $\sum F_x = 0$ ;  $\sum F_y = 0$ ;  $\sum M = 0$

### Friction

$$F = \mu N; \quad \mu = \tan \phi$$

### Energy, Work, Power

$$KE = \frac{1}{2}mv^2; \quad PE = mgh; \quad W = Fs = \Delta PE + \Delta KE; \quad P = \frac{W}{t}; \quad P = \frac{Fs}{t}; \quad P = Fv$$

### Pressure

$$P = \frac{F}{A}; \quad P = P_o + \rho gh$$

### Stress and Strain

$$\sigma = \frac{F}{A}; \quad \epsilon = \frac{e}{L}; \quad E = \frac{\sigma}{\epsilon}; \quad \sigma = \frac{My}{I}$$

$$\sigma_{\text{allowable}} = \frac{\sigma_{\text{yield}}}{F \text{ of } S} \text{ (Ductile);} \quad \sigma_{\text{allowable}} = \frac{\sigma_{\text{UTS}}}{F \text{ of } S} \text{ (Brittle)}$$

### Machines

$$MA = \frac{L}{E}; \quad VR = \frac{d_E}{d_L}; \quad \eta = \frac{MA}{VR}$$

### Digital Electronics

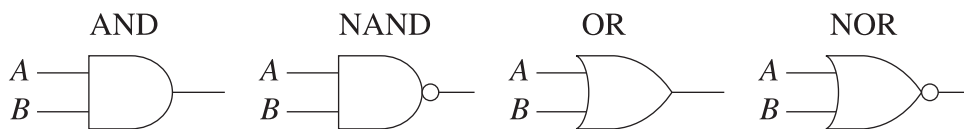

### Electricity, Electronics

$$E = IR \quad P = I^2R$$

Series  $R_t = R_1 + R_2 + R_3 + R_4 + \dots + R_n$

Parallel  $\frac{1}{R_t} = \frac{1}{R_1} + \frac{1}{R_2} + \frac{1}{R_3} + \frac{1}{R_4} + \dots + \frac{1}{R_n}$

BLANK PAGE